

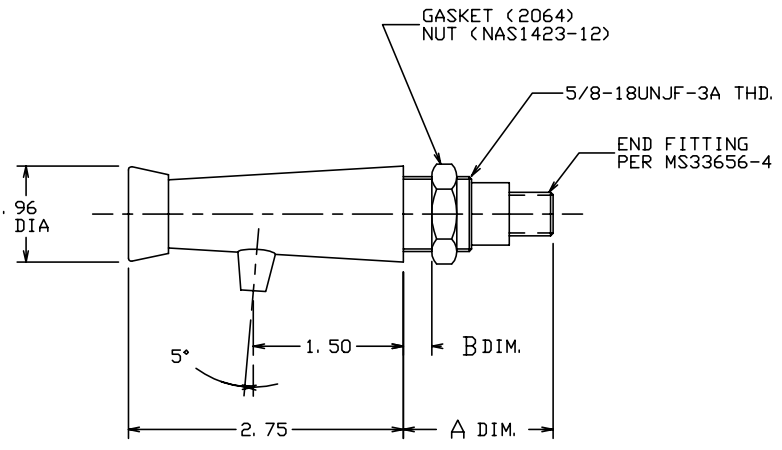

THE INFORMATION AND DESIGN HEREIN WAS ORIGINATED BY AND IS THE PROPERTY OF SKYLOCK INDUSTRIES INCORPORATED. SKYLOCK INDUSTRIES INCORPORATED RESERVES ALL PATENT, PROPRIETARY, DESIGN MANUFACTURING, REPRODUCTION, USE AND SALES RIGHTS THERE TO, AND TO ANY ARTICLE DISCLOSED THEREIN EXCEPT TO THE EXTENT RIGHTS ARE EXPRESSLY GRANTED TO OTHERS. THE FOREGOING DOES NOT APPLY TO VENDOR PROPRIETARY PARTS.

REVISIONS				
ZONE	LTR	DESCRIPTION	DATE	APPROVED
	NC	PRODUCTION RELEASE	2-3-93	T. CSIK
	A	ADDED -403	4-25-95	T. CSIK
	B	ADDED -405	4-28-95	T. CSIK

- NOTES: UNLESS OTHERWISE SPECIFIED.
- MAT'L: BUTTON & HOUSING; BRASS, VALVE ASSY; CRES.
  - DECORATIVE FINISH: SATIN CHROME PLATE.

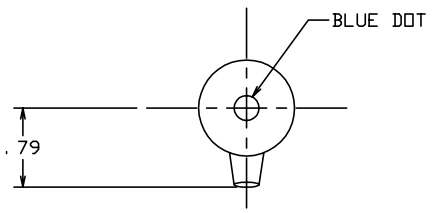

B DIM	A DIM	PART NO.	DESCRIPTION	MATERIAL SIZE SPECIFICATION	ITEM NO.
1.00	2.25	-405	SPIGOT ASSY	(NON-VENTING)	
1.00	2.25	-403	SPIGOT ASSY	(SELF-VENTING)	
.25	1.50	-401	SPIGOT ASSY	(SELF-VENTING)	

PARTS LIST		UNLESS OTHERWISE SPECIFIED		DRAWN BY T. CSIK 2-3-93		 SKYLOCK INDUSTRIES INCORPORATED MONROVIA CALIFORNIA U. S. A.
DIMENSIONS ARE IN INCHES		CHECKED		ENGINEER		
TOLERANCES ON		PROJECT		APPROVAL T. CSIK 2-3-93		
DECIMALS ANGLES DRILLED HOLES		APPROVAL				
.X ± .1 ± 0° 30' AND 10387		DO NOT SCALE THIS DRAWING		MATERIAL - FINISH		SPIGOT ASSY  SCALE 1/1
.XX ± .03		USED ON		SIZE CODE IDENT. NO. DRAWING NO.		
.XXX ± .010		NEXT ASSY		C 51941 90053		
		FINAL ASSY		SCALE 1/1		REV. B SHEET 1 OF 1

FLUID MEDIA	OPERATING PRESSURE	OPERATING TEMP.	FLOW
POTABLE WATER	0-120 PSIG	35°F TO 225°F	100/140 OZ. /MIN. AT 70°F AND 30 P. S. I. INLET PRESSURE