

THE INFORMATION AND DESIGN HEREIN WAS ORIGINATED BY AND IS THE PROPERTY OF SKYLOCK INDUSTRIES INCORPORATED. SKYLOCK INDUSTRIES INCORPORATED RESERVES ALL PATENT, PROPRIETARY, DESIGN MANUFACTURING, REPRODUCTION, USE AND SALES RIGHTS THERE TO, AND TO ANY ARTICLE DISCLOSED THEREIN EXCEPT TO THE EXTENT RIGHTS ARE EXPRESSLY GRANTED TO OTHERS. THE FOREGOING DOES NOT APPLY TO VENDOR PROPRIETARY PARTS.

REVISIONS				
ZONE	LTR	DESCRIPTION	DATE	APPROVED
	NC	PRODUCTION RELEASE	5. 4. 92	SC

D

C

B

A

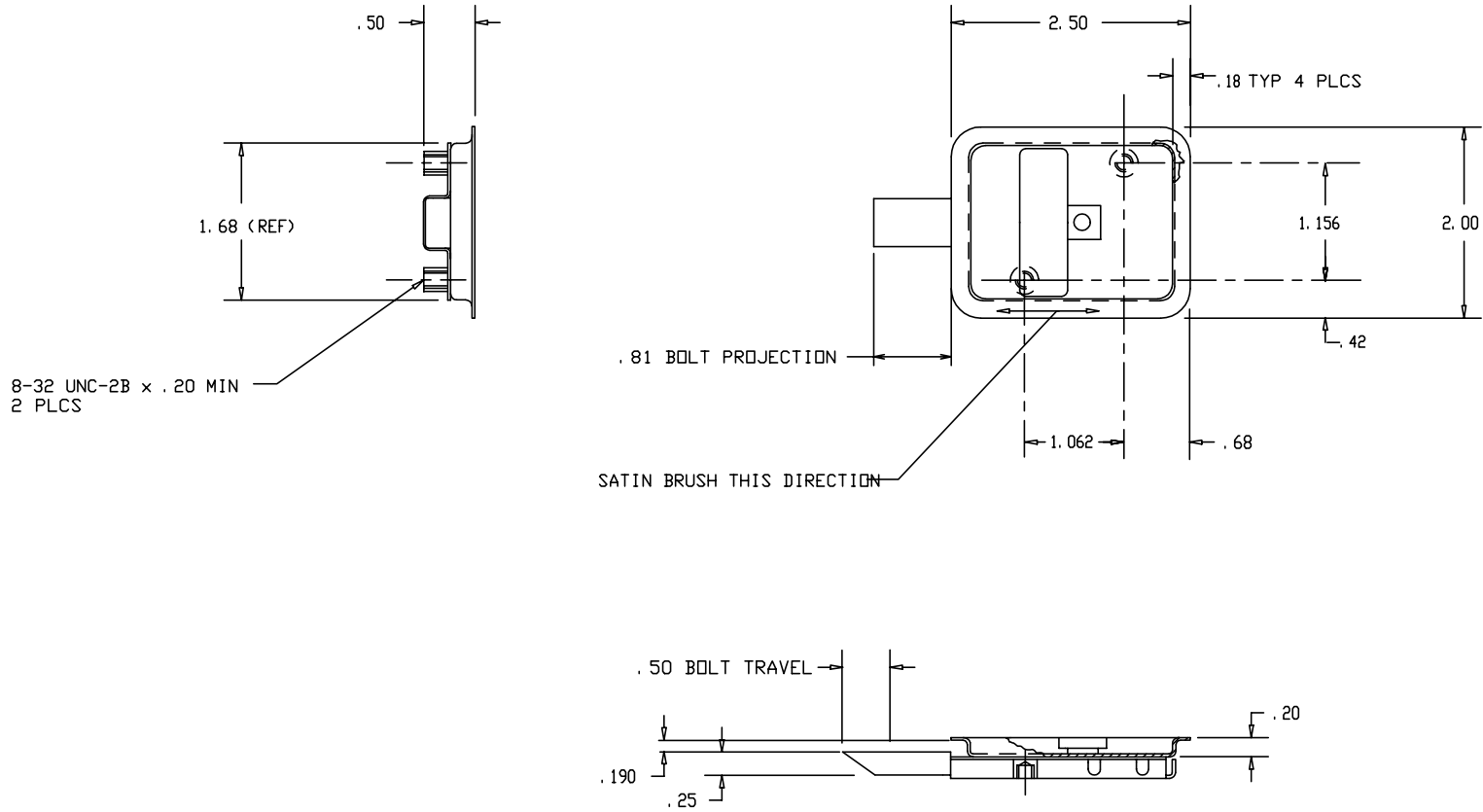

8-32 UNC-2B x .20 MIN
2 PLCS

.81 BOLT PROJECTION

SATIN BRUSH THIS DIRECTION

.50 BOLT TRAVEL

7. DECORATIVE FINISH: INSIDE CASE; SATIN MATTE; FLANGE; SATIN BRUSH (DIRECTION INDICATED)
6. LATCH IS SPRING LOADED OUTWARD
5. LATCH HAS GREEN AND RED DOTS TO INDICATE BOLT ENGAGEMENT AND DISENGAGEMENT RESPECTIVELY
4. STATIC LOAD: 700 LBS MAX
3. FINISH: ALUM; CLEAR ANODIZE PER MIL-A-8625; CRES; PASSIVATE PER MIL-S-5002
2. MAT'L: HANDLE AND CROSSBAR; 6061-T6 ALUM ALLOY; CASE, BOLT AND ALL OTHER COMPONENTS; 300 SERIES CRES
1. REMOVE ALL BURRS AND SHARP EDGES

NOTES: UNLESS OTHERWISE SPECIFIED

QTY. / REV'D		PART / IDENT NO.	DESCRIPTION	MATERIAL / SPECIFICATION	ITEM NO.
		-1	LATCH ASSY		
UNLESS OTHERWISE SPECIFIED DIMENSIONS ARE IN INCHES			CONTRACT NO.	SKYLOCK INDUSTRIES INCORPORATED MONROVIA, CALIFORNIA, USA	
TOLERANCES			CUSTOMER		
DECIMALS	.XX	.00	DRAWN BY	DATE	LATCH ASSY
ANGULAR	.XXX	.010	S. CSIK		
DO NOT SCALE DRAWING		CHECK			
NEXT ASSY	FINAL ASSY		DESIGN		
USED ON	DESIGN ACTIVITY		SIZE	FSCN NO.	DRAWING NO.
FINISH	ACT WT	CALC WT	C	51941	20772
			SCALE	RELEASE DATE	SHEET
			1/1	5. 4. 92	1 OF 1

4

3

2

1

DRAWING NO.

SHEET

A