

THE INFORMATION AND DESIGN HEREIN WAS ORIGINATED BY AND IS THE PROPERTY OF SKYLOCK INDUSTRIES INCORPORATED. SKYLOCK INDUSTRIES INCORPORATED RESERVES ALL PATENT, PROPRIETARY, DESIGN MANUFACTURING, REPRODUCTION, USE AND SALES RIGHTS THEREON, AND TO ANY ARTICLE DISCLOSED THEREIN EXCEPT TO THE EXTENT RIGHTS ARE EXPRESSLY GRANTED TO OTHERS. THE FOREGOING DOES NOT APPLY TO VENDOR PROPRIETARY PARTS.

REVISIONS				
ZONE	LTR.	DESCRIPTION	DATE	APPROVED
	NC	PRODUCTION RELEASE	8.14.91	SC
	A	REVISED BACKPLATE FINISH	9.5.91	SC

NOTES: UNLESS OTHERWISE SPECIFIED

1. REMOVE ALL BURRS AND SHARP EDGES
2. MAT'L: CASE AND BACKPLATE; ALUM ALLOY
3. FINISH: CASE; SATIN BRUSH AND CLEAR ANODIZE PER MIL-A-8625E; BACKPLATE; GEORGIAN GREY WRINKLE POWDER COAT, MORTON 12-7002

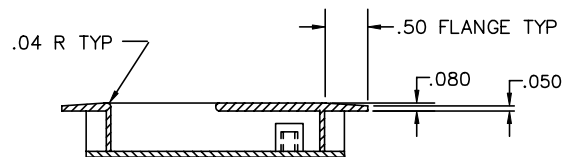
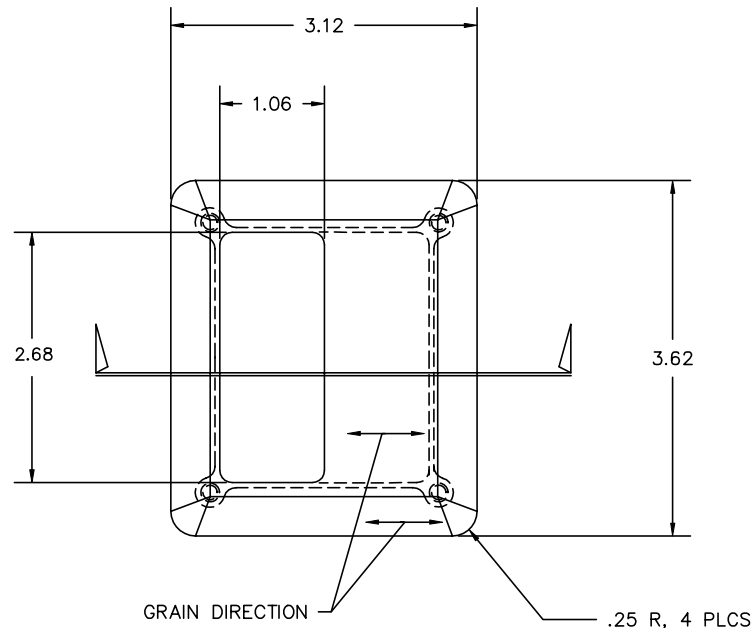
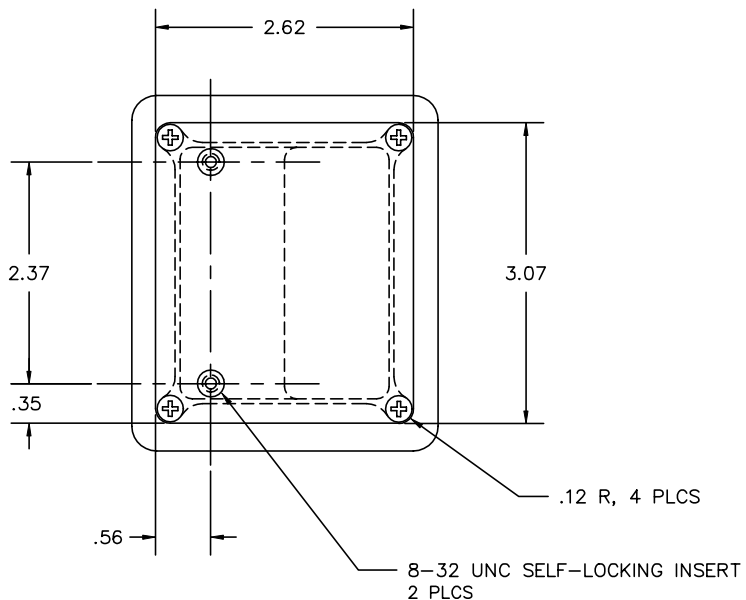

.68		-3	HANDLE ASSY		
.48		-1	HANDLE ASSY		
A	QTY. REQ'D	PART / IDENT NO.	DESCRIPTION	MATERIAL / SPECIFICATION	ITEM NO.
	UNLESS OTHERWISE SPECIFIED: DIMENSIONS ARE IN INCHES		CONTRACT NO.	 <b>SKYLOCK INDUSTRIES INCORPORATED</b> MONROVIA, CALIFORNIA, USA	A
	TOLERANCES DECIMALS .XX ±.03 .XXX ±.010		CUSTOMER		
	ANGULAR ± 0 30'		DRAWN BY S. CSIK	HANDLE ASSY	A
	DO NOT SCALE DRAWING		DATE		
	NEXT ASSY	FINAL ASSY	DESIGN		
	USED ON		DESIGN ACTIVITY	SIZE C	REV. A
	FINISH	ACT WT	CALC WT	FSCM NO. 51941	DRAWING NO. 20720
				SCALE 1/1	RELEASE DATE 8.14.91
					SHEET 1 OF 1