

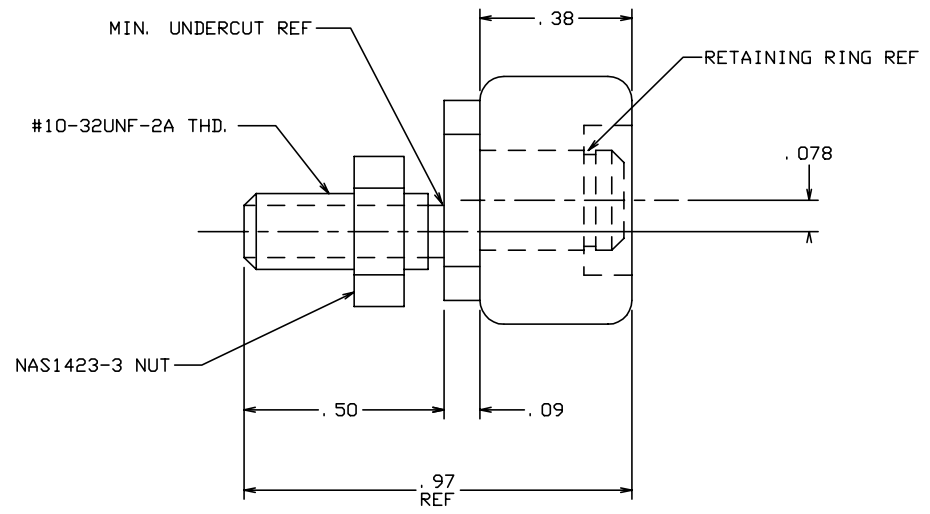

THE INFORMATION AND DESIGN HEREIN WAS ORIGINATED BY AND IS THE PROPERTY OF SKYLOCK INDUSTRIES INCORPORATED. SKYLOCK INDUSTRIES INCORPORATED RESERVES ALL PATENT, PROPRIETARY, DESIGN MANUFACTURING, REPRODUCTION, USE AND SALES RIGHTS THERE TO, AND TO ANY ARTICLE DISCLOSED THEREIN EXCEPT TO THE EXTENT RIGHTS ARE EXPRESSLY GRANTED TO OTHERS. THE FOREGOING DOES NOT APPLY TO VENDOR PROPRIETARY PARTS.

REVISIONS				
ZONE	LTR	DESCRIPTION	DATE	APPROVED
	NC	PRODUCTION RELEASE	5-14-92	T. CSIK

- NOTES: UNLESS OTHERWISE SPECIFIED.
1. REMOVE ALL BURRS AND BREAK SHARP EDGES.
  2. MAT'L: ROLLER; NYLON, AXLE; ST. STL.
  3. FINISH: ST. STL.; PASSIVATE.

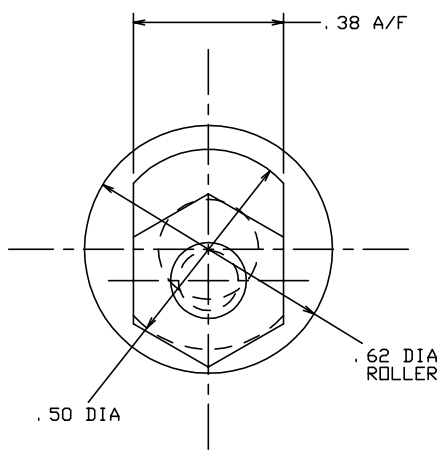

		-401	ROLLER ASSY			
QTY REQD	PART NO.	DESCRIPTION		MATERIAL SIZE SPECIFICATION		ITEM NO.
PARTS LIST						
UNLESS OTHERWISE SPECIFIED			DRAWN BY	T. CSIK	5-14-92	 SKYLOCK INDUSTRIES INCORPORATED MONROVIA CALIFORNIA U. S. A.
DIMENSIONS ARE IN INCHES			CHECKED			
TOLERANCES ON			ENGINEER			
DECIMALS ANGLES DRILLED HOLES			PROJECT			
.X ± .1 ± 0° 30' AND 10387			APPROVAL	T. CSIK	5-14-92	
.XX ± .03						
.XXX ± .010						
DO NOT SCALE THIS DRAWING			APPROVAL			
MATERIAL - FINISH		USED ON		SIZE	CODE IDENT. NO.	DRAWING NO.
NEXT ASSY				C	51941	20773
FINAL ASSY				SCALE	4: 1	WT.
				SHEET 1 OF 1		REV. NC