

THE INFORMATION AND DESIGN HEREIN WAS ORIGINATED BY AND IS THE PROPERTY OF SKYLOCK INDUSTRIES INCORPORATED. SKYLOCK INDUSTRIES INCORPORATED RESERVES ALL PATENT, PROPRIETARY, DESIGN MANUFACTURING, REPRODUCTION, USE AND SALES RIGHTS THERE TO, AND TO ANY ARTICLE DISCLOSED THEREIN EXCEPT TO THE EXTENT RIGHTS ARE EXPRESSLY GRANTED TO OTHERS. THE FOREGOING DOES NOT APPLY TO VENDOR PROPRIETARY PARTS.

REVISIONS				
ZONE	LTR	DESCRIPTION	DATE	APPROVED
	NC	PRODUCTION RELEASE	11-11-88	T. S.
	A	REDRAWN, ADDED -403/-404	4-4-95	T. CSIK

- NOTES: UNLESS OTHERWISE SPECIFIED.
- REMOVE ALL BURRS AND BREAK SHARP EDGES.
 - MAT'L: RETAINER; ALUM. ALLOY, ALL OTHER PARTS; 300 SERIES CRES.
 - FINISH: ALUM.; ANODIZE, CRES PARTS; PASSIVATE.
 - DECORATIVE FINISH: RETAINER; BRIGHT BUFF AND CANDY APPLE RED ANODIZE.
 - SHAFT NEEDS NO TORQUE ADJUSTMENT. TIGHTEN SHAFT AS MUCH AS POSSIBLE WHEN INSTALLING RETAINER.

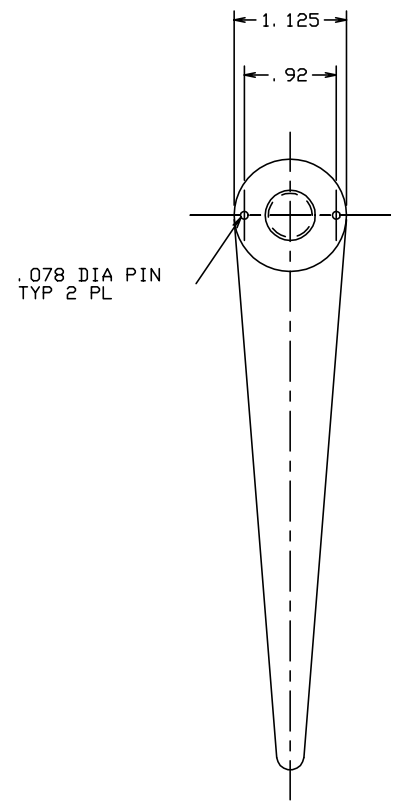
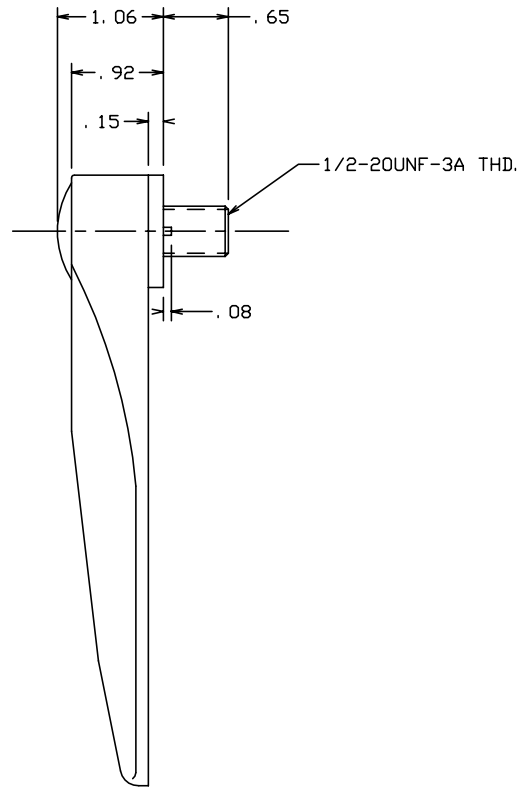
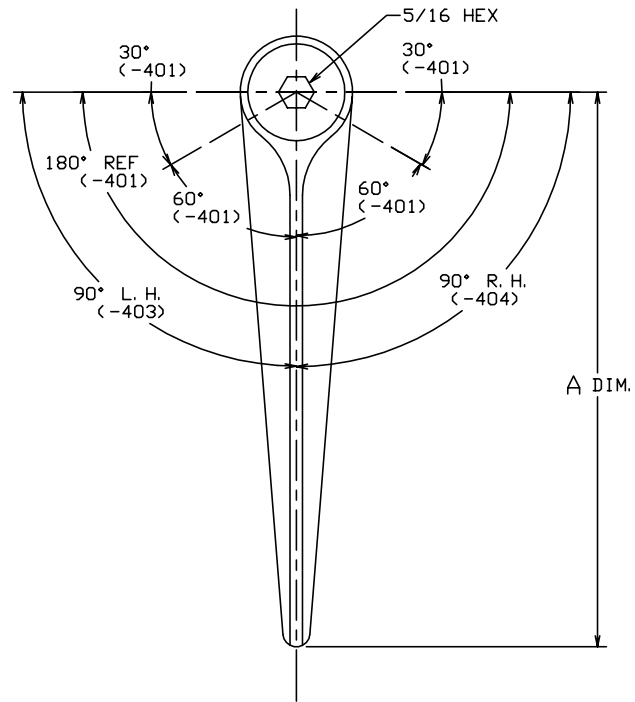

5. 55	-404	RETAINER ASSY	<90° RIGHT HAND
5. 55	-403	RETAINER ASSY	<90° LEFT HAND
5. 55	-401	RETAINER ASSY	<180°, DETENTED AT 30° & 90°
A DIM	PART NO.	DESCRIPTION	MATERIAL SIZE SPECIFICATION
PARTS LIST			
UNLESS OTHERWISE SPECIFIED		DRAWN BY T. CSIK	4-4-95
DIMENSIONS ARE IN INCHES		CHECKED	
TOLERANCES ON		ENGINEER	
DECIMALS ANGLES DRILLED HOLES		PROJECT	
.X ± .1 ± 0° 30' AND 10387		APPROVAL	
.XX ± .03		APPROVAL	
.XXX ± .010		APPROVAL	
DO NOT SCALE THIS DRAWING			
MATERIAL - FINISH		USED ON	SIZE CODE IDENT. NO. DRAWING NO. REV.
NEXT ASSY			C 51941 20633 A
FINAL ASSY			SCALE 1: 1 WT. SHEET 1 OF 1

SKYLOCK INDUSTRIES INCORPORATED
MONROVIA CALIFORNIA U. S. A.

1/4 TURN RETAINER