

LATCH TO BE USED WITH 20293-1
 PLATE ASSY (-1,-3 ONLY)

REVISIONS			
SYM	DESCRIPTION	DATE	BY
A	REVISE HANDLE	11-27-78	JEE
B	ADD -5	1-3-79	JEE
C	ADD -7 LATCH	1-6-82	747

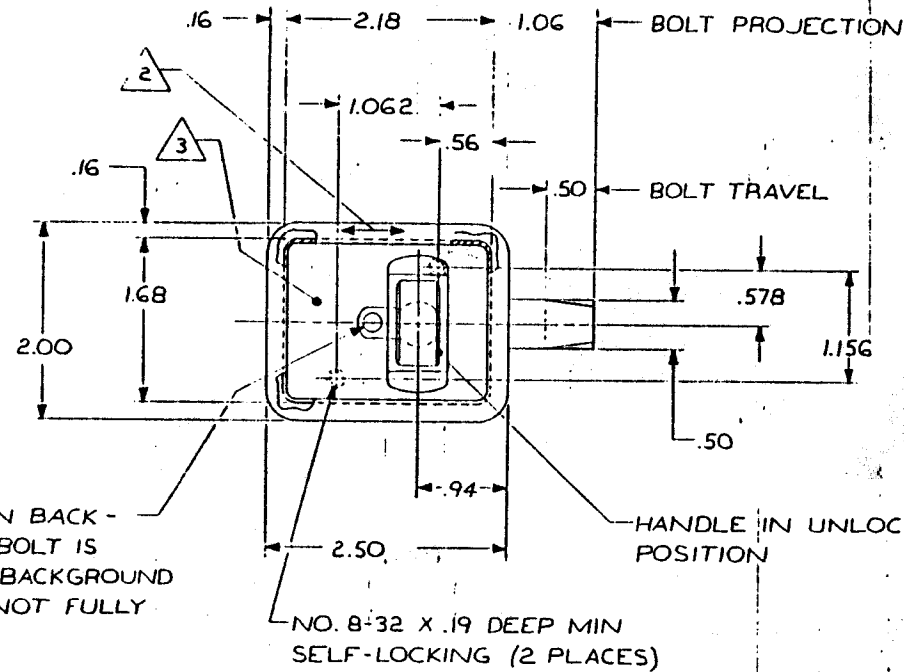

AREA HAS GREEN BACK-GROUND WHEN BOLT IS EXTENDED-RED BACKGROUND WHEN BOLT IS NOT FULLY LATCHED

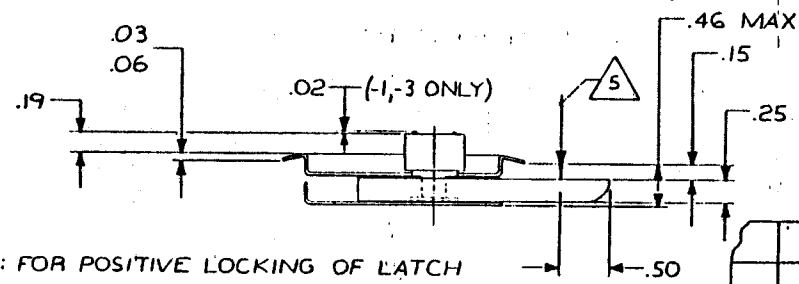
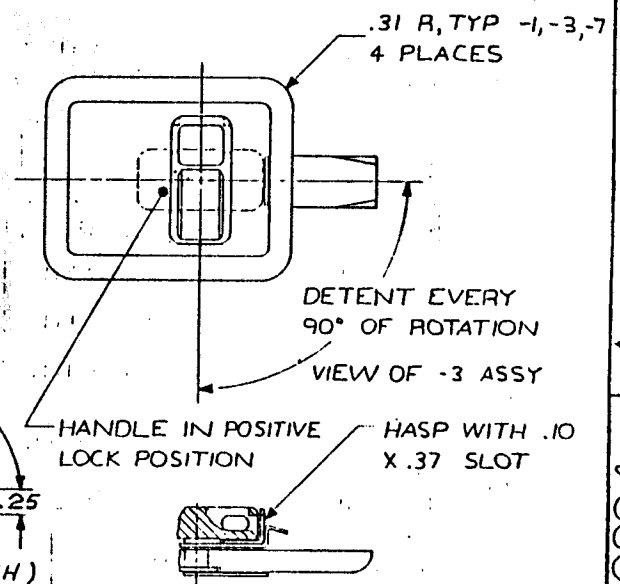

6. OPERATION: FOR POSITIVE LOCKING OF LATCH ASSY, ROTATE HANDLE 90 DEGREES CLOCKWISE OR COUNTER CLOCKWISE, HANDLE IS DETENTED IN THIS POSITION TO UNLOCK ROTATE HANDLE CLOCKWISE OR COUNTER CLOCKWISE
5. STATIC LOAD: 600 LBS AS SHOWN WHEN PROPERLY INSTALLED
4. PROTECTIVE FINISH: CRES-PASSIVATE, STEEL-CAD PLATE,
3. DECORATIVE FINISH: SATIN MATTE
2. DECORATIVE FINISH: SATIN BUFF
1. MAT'L: HANDLE-ALUM, MAGNET ASSY-CERAMIC & STEEL, ALL OTHER PARTS-CRES

NOTES: UNLESS OTHERWISE SPECIFIED

PART NUMBER	DESCRIPTION	MATERIAL OR NOTE
-7	LATCH ASSY-SLAM	(SAME AS -3 EXCEPT AS NOTED)
-5	LATCH ASSY-DETENTED	WITH HASP, NO MAGNET
-3	LATCH ASSY-DETENTED	WITH HASP
-1	LATCH ASSY-DETENTED	WITHOUT HASP

REQD		LIST OF MATERIAL	
UNLESS OTHERWISE NOTED DIMENSIONS ARE IN INCHES. TOLERANCES ON: DECIMALS .XX ± .03 .XXX ± .010 ANGLES ± DRILLED HOLES PER ANSI B3.1	CONTRACT NO.	SKYLOCK INDUSTRIES, INC. SO. EL MONTE, CALIFORNIA	
SURFACE ROUGHNESS	DRAFTSMAN JEE 1/17/78	LATCH ASSEMBLY	
HEAT TREAT	CHECKER	SIZE C	CODE IDENT NO. 51941
FINISH	ENGINEER JEE 1/17/78	20294	
INSPECT	PROD. APPD	SCALE 1/1	WT CALC
REF. NO.	APPROVAL [Signature]	WT ACT	SHEET 1 OF 1
NEXT ASSY	USED ON		
APPLICATION			