

THE INFORMATION AND DESIGN HEREIN WAS ORIGINATED BY AND IS THE PROPERTY OF SOLIDIX INDUSTRIES INCORPORATED. SOLIDIX INDUSTRIES INCORPORATED RESERVES ALL PATENT, PROPRIETARY, DESIGN MANUFACTURING INFORMATION, USE AND SALES RIGHTS HEREIN, AND TO ANY ARTICLES DEVELOPED THEREIN EXCEPT TO THE EXTENT RIGHTS ARE EXPRESSLY GRANTED TO OTHERS. THE FOREGOING DOES NOT APPLY TO NON-PATENTABLE PARTS.

- NOTES: UNLESS OTHERWISE SPECIFIED.
1. REMOVE ALL BURRS AND BREAK SHARP EDGES.
 2. MAT'L: *D* HANDLE AND TEE BAR, 6061-T6 ALUM. ALLOY, ALL OTHER PARTS, 300 SERIES CRES.
 3. FINISH: ALUM., CLEAR ANODIZE PER MIL-A-8625E. ST. STL. CLEAN AND PASSIVATE.
 4. DECORATIVE FINISH: HANDLE AND CUP ARE SATIN BRUSHED ON TOP SURFACES.
 5. BOLTS ARE SPRING LOADED TO THE ENGAGED POSITION.
 6. *D* HANDLE TO BE SPRING LOADED DOWN.
 7. USE WITH 20177-3 BACKPLATE, ORDERED SEPARATELY.

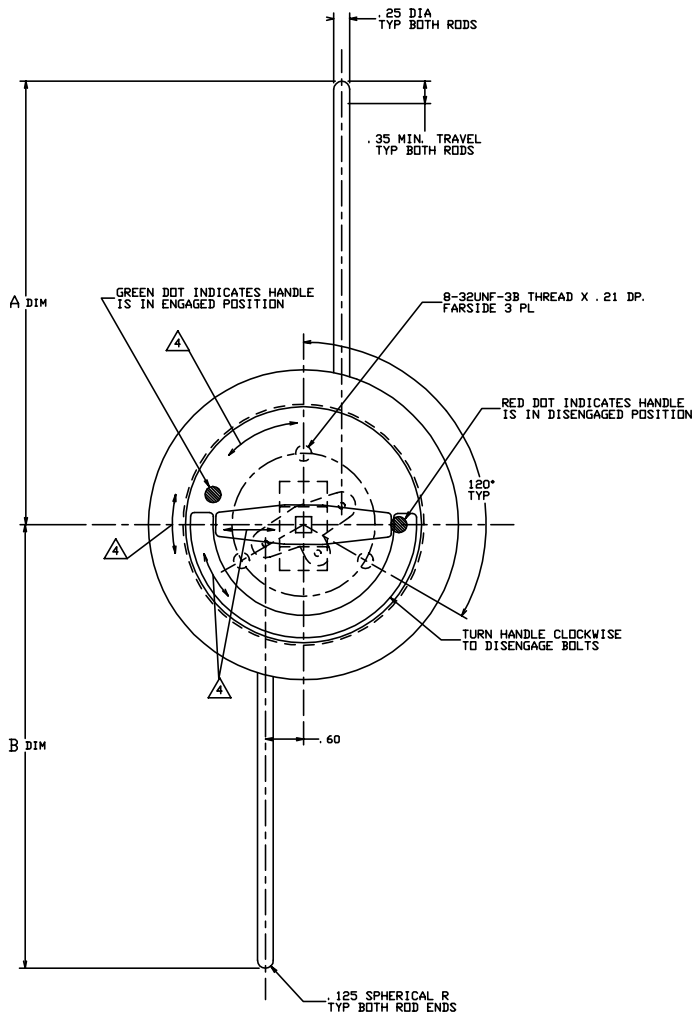

REVISIONS				
ZONE	LTR	DESCRIPTION	DATE	APPROVED
NC		PRODUCTION RELEASE	2-12-96	T. C.

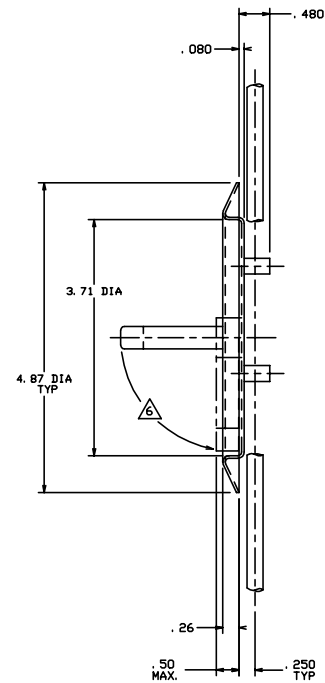

SEE TABULATION BLOCK FOR ORDERING INFORMATION

	-402	BOLTING SYSTEM	(DPP. -401)	
	-401	BOLTING SYSTEM	(SHOWN)	
QTY REQD	PART NO.	DESCRIPTION	MATERIAL, SIZE, SPECIFICATION	ITEM NO.
PARTS LIST				
UNLESS OTHERWISE SPECIFIED		DRAWN BY	T. CSIK	2-12-96
DIMENSIONS ARE IN INCHES		CHECKED		
TOLERANCES ON		ENGINEER		
DECIMALS		PROJECT		
ANGLES		APPROVAL	T. CSIK	2-12-96
DILLED HOLES		APPROVAL		
.0005		USED ON		
.001		SIZE	D	CODE IDENT. NO.
.002		NEXT ASBY	51941	DRAWING NO.
.005		FINAL ASBY		20919
		SCALE	1:1	REV.
				NC
				1 OF 1

EXAMPLE:

20919-401-100-100

A DIM. @ 10.0 INCHES
B DIM. @ 10.0 INCHES

	FIRST TWO DIGITS (INCHES) THIRD DIGIT (TENTH IN.) A DIM.	FIRST TWO DIGITS (INCHES) THIRD DIGIT (TENTH IN.) B DIM.
-402		
-401		
FIRST DASH NO.	SECOND DASH NO.	THIRD DASH NO.

TABULATION BLOCK