

THE INFORMATION AND DESIGN HEREIN WAS ORIGINATED BY AND IS THE PROPERTY OF SKYLOCK INDUSTRIES INCORPORATED. SKYLOCK INDUSTRIES INCORPORATED RESERVES ALL PATENT, PROPRIETARY, DESIGN MANUFACTURING, REPRODUCTION, USE AND SALES RIGHTS THERE TO, AND TO ANY ARTICLE DISCLOSED THEREIN EXCEPT TO THE EXTENT RIGHTS ARE EXPRESSLY GRANTED TO OTHERS. THE FOREGOING DOES NOT APPLY TO VENDOR PROPRIETARY PARTS.

REVISIONS:				
ZONE	LTR	DESCRIPTION	DATE	APPROVED
NC		PRODUCTION RELEASE	10/90	SC
A		REDRAWN AND REVISED	12-28-90	JL
B		ADD SELF-LOCKING THD.	2-8-91	JL
C		REVISED AND REDRAWN	3-22-91	TC

- NOTES: UNLESS OTHERWISE SPECIFIED
1. REMOVE ALL BURRS AND SHARP EDGES
 2. MAT'L: ROLLER BLOCK CHASSIS; 6061-T6 ALUM ALLOY; ROLLERS; BLACK NYLON 6/6; ALL OTHER PARTS; CRES
 3. FINISH: ALUM.; BLACK ANODIZE CRES; PASSIVATE

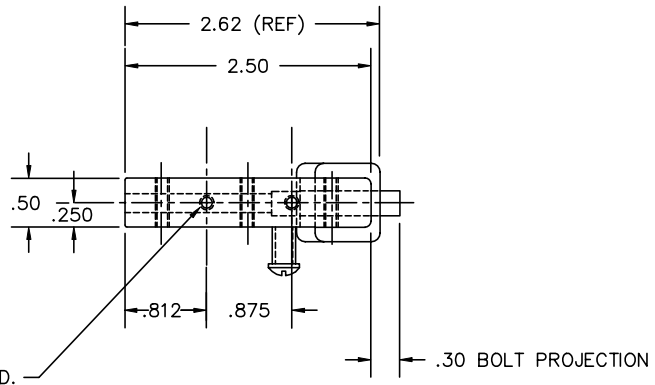

6-32UNC SELF-LOCKING THD.
x .50 DP 2 PLCS

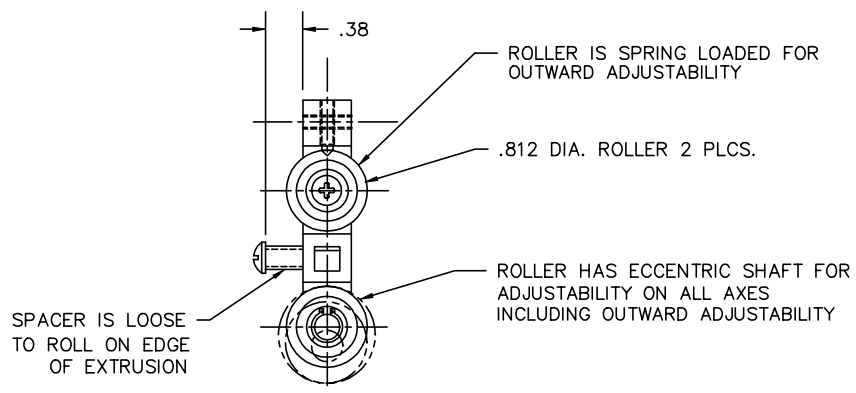
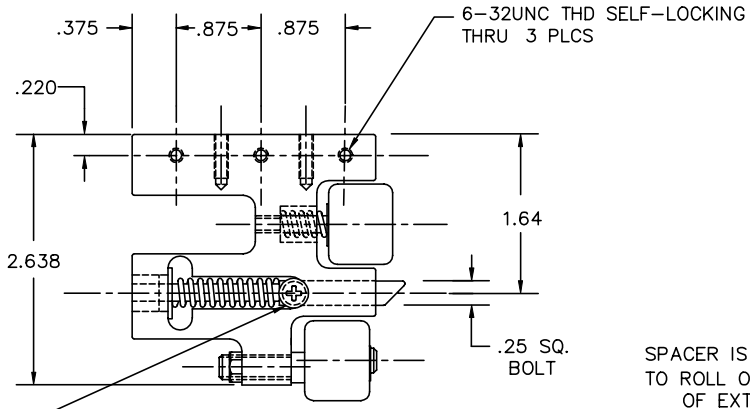

	-402	ROLLER BLOCK ASSY	OPPOSITE										
	-401	ROLLER BLOCK ASSY	SHOWN										
QTY REQ'D	PART / IDENT NO.	DESCRIPTION	MATERIAL / SPECIFICATION	ITEM NO.									
UNLESS OTHERWISE SPECIFIED: DIMENSIONS ARE IN INCHES		CONTRACT NO.		 SKYLOCK INDUSTRIES INCORPORATED MONROVIA, CALIFORNIA, USA ROLLER BLOCK ASSY									
TOLERANCES		DRAWN BY	DATE										
DECIMALS .XX ± .03 .XXX ± .010	ANGULAR ± 0 30'	SC	10/90										
DO NOT SCALE DRAWING		CHECK	3-22-91										
NEXT ASSY		DESIGN	SC	10/90									
USED ON		DESIGN ACTIVITY		SIZE									
FINISH		ACT WT	CALC WT	CUSTOMER	<table border="1"> <tr> <td>SIZE</td> <td>FSCM NO.</td> <td>DRAWING NO.</td> <td>REV.</td> </tr> <tr> <td>C</td> <td>51941</td> <td>20688</td> <td>C</td> </tr> </table>	SIZE	FSCM NO.	DRAWING NO.	REV.	C	51941	20688	C
SIZE	FSCM NO.	DRAWING NO.	REV.										
C	51941	20688	C										
NOTED		SCALE 1/1		RELEASE DATE 10/16/90 SHEET 1 OF 1									

DRAWING NO. 20688