

THE INFORMATION AND DESIGN HEREIN WAS ORIGINATED BY AND IS THE PROPERTY OF SKYLOCK INDUSTRIES INCORPORATED. SKYLOCK INDUSTRIES INCORPORATED RESERVES ALL PATENT, PROPRIETARY, DESIGN MANUFACTURING, REPRODUCTION, USE AND SALES RIGHTS THERETO, AND TO ANY ARTICLE DISCLOSED THEREIN EXCEPT TO THE EXTENT RIGHTS ARE EXPRESSLY GRANTED TO OTHERS. THE FOREGOING DOES NOT APPLY TO VENDOR PROPRIETARY PARTS.

REVISIONS				
ZONE	LTR.	DESCRIPTION	DATE	APPROVED
	NC	PRODUCTION RELEASE	8.26.91	SC
	A	ADDED -3	9.13.91	SC
	B	ADDED -5	7.14.92	SC

NOTES: UNLESS OTHERWISE SPECIFIED

1. REMOVE ALL BURRS AND SHARP EDGES
2. MAT'L: HANDLE; ALUM ALLOY; ALL OTHER COMPONENTS; 300 SERIES CRES
3. FINISH: ALUM; SATIN BRUSH AND CLEAR ANODIZE; CRES PARTS; PASSIVATE
4. STATIC LOAD: 800 LBS
5. BOLT IS DETENTED IN ENGAGED AND DISENGAGED POSITIONS

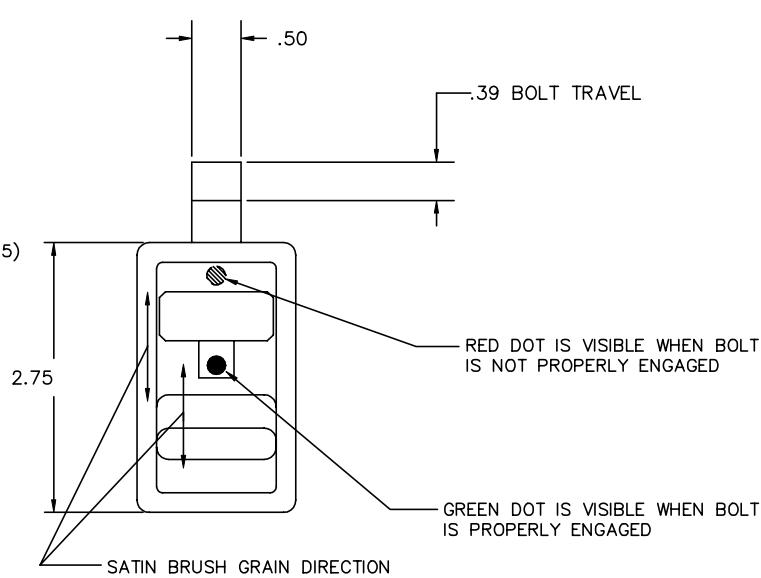
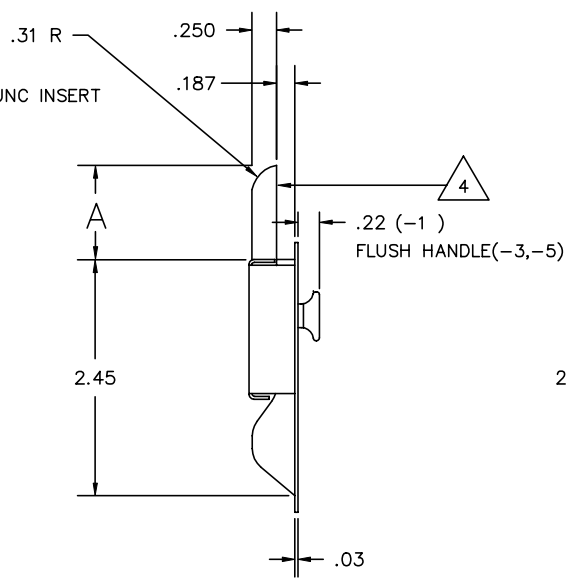
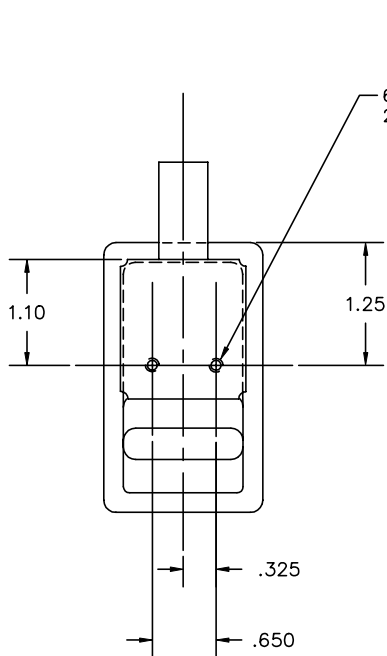
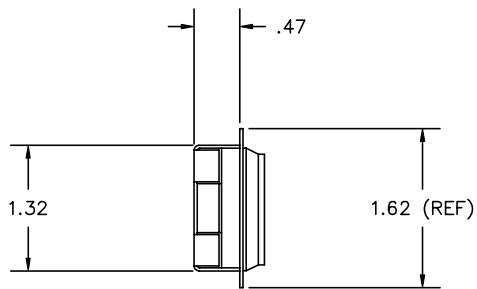

.59		-5	LATCH ASSY		
.82		-3	LATCH ASSY		
.82		-1	LATCH ASSY		
A	QTY. REQ'D	PART / IDENT NO.	DESCRIPTION	MATERIAL / SPECIFICATION	ITEM NO.
UNLESS OTHERWISE SPECIFIED: DIMENSIONS ARE IN INCHES			CONTRACT NO.	SKYLOCK INDUSTRIES INCORPORATED MONROVIA, CALIFORNIA, USA	
TOLERANCES			CUSTOMER		
DECIMALS .XX ±.03		ANGULAR ± 0 30'	DRAWN BY S. CSIK	DATE	LATCH ASSY-- DEAD BOLT
DO NOT SCALE DRAWING		CHECK			
NEXT ASSY	FINAL ASSY	DESIGN			
USED ON	DESIGN ACTIVITY		SIZE C	FSCM NO. 51941	DRAWING NO. 20725
FINISH	ACT WT	CALC WT	SCALE 1/1	RELEASE DATE 8.26.91	SHEET 1 OF 1

DRAWING NO.

SHEET OF

A