

THE INFORMATION AND DESIGN HEREIN WAS ORIGINATED BY AND IS THE PROPERTY OF SKYLOCK INDUSTRIES INCORPORATED. SKYLOCK INDUSTRIES INCORPORATED RESERVES ALL PATENT, PROPRIETARY, DESIGN MANUFACTURING, REPRODUCTION, USE AND SALES RIGHTS THERE TO, AND TO ANY ARTICLE DISCLOSED THEREIN EXCEPT TO THE EXTENT RIGHTS ARE EXPRESSLY GRANTED TO OTHERS. THE FOREGOING DOES NOT APPLY TO VENDOR PROPRIETARY PARTS.

REVISIONS				
ZONE	LTR	DESCRIPTION	DATE	APPROVED
	NC	PRODUCTION RELEASE	9/21/95	SC
	A	SEE ECN A	4/6/99	TC

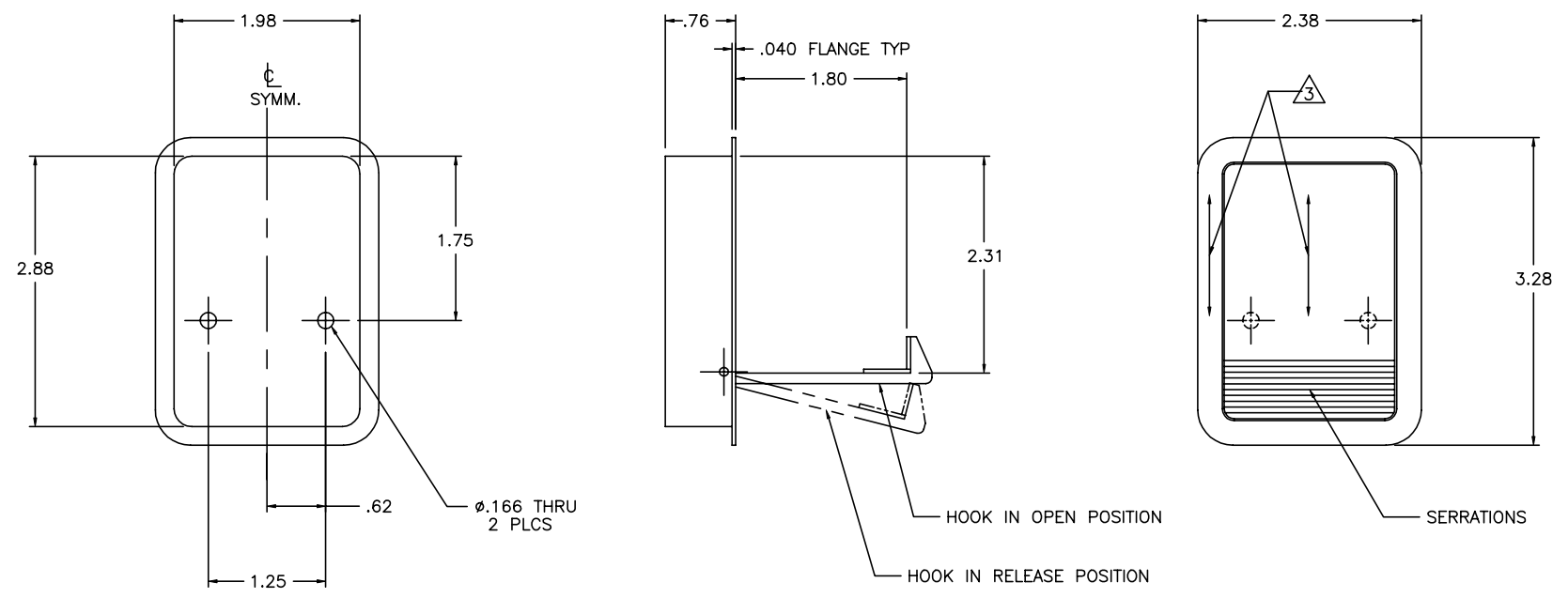

-1 DOOR RETAINER

5. PER FAR 45.15. PARTS WILL BE IDENTIFIED WITH:

1. FAA-PMA.
2. SKYLOCK IND. INC.
3. PART NO.
4. AIRCRAFT ELIGIBILITY.

4. HOOK IS SPRING LOADED TO RETRACTED POSITION, PRESS SERRATED AREA TO POSITION HOOK FOR DOOR RETENTION.

3 FINISH REF: ALUMINUM; SATIN BRUSH, DIRECTION NOTED AND CLEAR ANODIZE PER MIL-A-8625, TYPE II, CLASS 1. CRES; PASSIVATE.

2. MAT'L REF: HOUSING AND HOOK, 60601-T6/T651 PER ASTM B-221, OR EQUIV. ALL OTHER MAT'L; CRES

1. REMOVE ALL BURRS AND SHARP EDGES

NOTES: UNLESS OTHERWISE SPECIFIED:

QTY REQ		PART NO.	DESCRIPTION	MATERIAL	SIZE	APPLICATION	MAKE FROM
		-1	DOOR RETAINER				120914-1
PARTS LIST							
UNLESS OTHERWISE SPECIFIED				DRAWN BY	S. CSIK	9/21/95	SKYLOCK INDUSTRIES INCORPORATED MONROVIA CALIFORNIA U. S. A.
DIMENSIONS ARE IN INCHES				CHECKED	ED WELSH	3/30/99	
TOLERANCES ON				ENGINEER	T. CSIK	4/6/99	
DECIMALS ON				MFG	P. MATSUOKA	4/12/99	
ANGLES DRILLED HOLES				Q. C.	J. VIVIRITO	4/20/99	
DO NOT SCALE THIS DRAWING				USED ON			
MATERIAL - FINISH				SIZE	CODE IDENT. NO.	DRAWING NO.	REV.
MANUFACTURED IN ACCORDANCE WITH SKYLOCK IND. INC. QUALITY CONTROL MANUAL QC.001				C	51941	20914	A
				SCALE	1:1	VT.	SHEET 1 OF 1