

THE INFORMATION AND DESIGN HEREIN WAS ORIGINATED BY AND IS THE PROPERTY OF SKYLOCK INDUSTRIES INCORPORATED. SKYLOCK INDUSTRIES INCORPORATED RESERVES ALL PATENT, PROPRIETARY, DESIGN MANUFACTURING, REPRODUCTION, USE AND SALES RIGHTS THERETO, AND TO ANY ARTICLE DISCLOSED THEREIN EXCEPT TO THE EXTENT RIGHTS ARE EXPRESSLY GRANTED TO OTHERS. THE FOREGOING DOES NOT APPLY TO VENDOR PROPRIETARY PARTS.

REVISIONS				
ZONE	LTR.	DESCRIPTION	DATE	APPROVED
	B	ADDED -3 AND -4	8.20.93	SC

NOTES: UNLESS OTHERWISE SPECIFIED

- REMOVE ALL BURRS AND SHARP EDGES
- MATERIAL: HOUSING, HANDLE AND BACKPLATE; 6061-T6 ALUM.
ALL OTHER PARTS; SERIES 300 CRES
- FINISH: ALUM; CLEAR ANODIZE
ALL OTHER PARTS; PASSIVATE
- LATCH IS DETENTED IN EXTENDED AND RETRACTED POSITIONS.

5. GREEN DOT IS VISIBLE WHEN BOLT IS EXTENDED

6. RED DOT IS VISIBLE WHEN BOLT IS RETRACTED

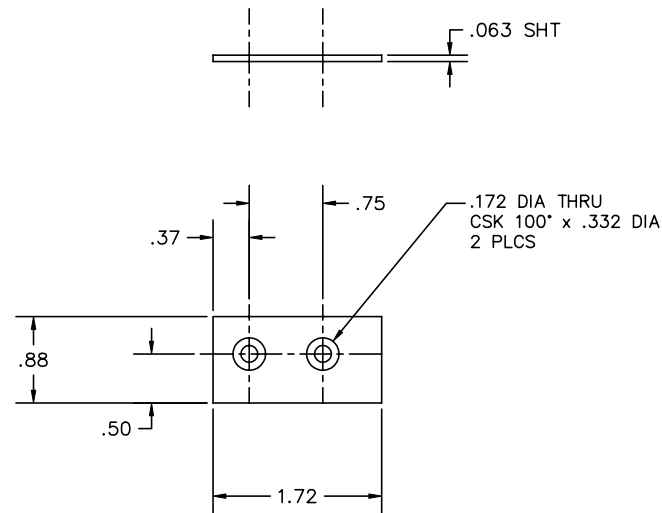
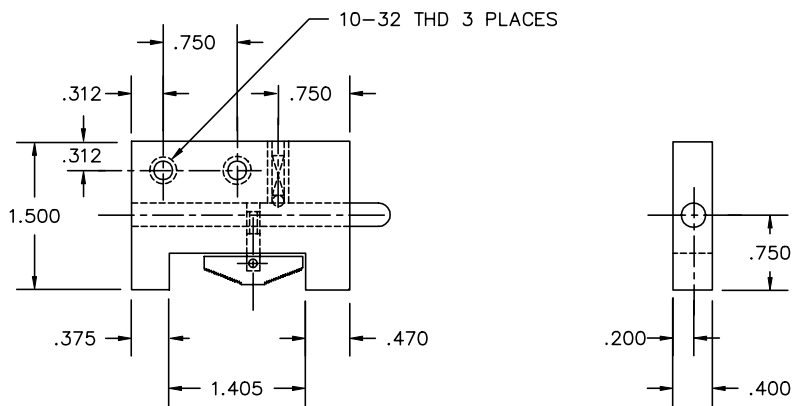

-3 BACKPLATE SHOWN

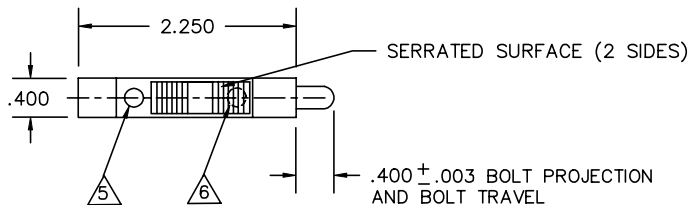

	-4	BACKPLATE	(OPP)	
	-3	BACKPLATE	(SHOWN)	
	-401	LATCH ASSY		
QTY. REQ'D	PART / IDENT NO.	DESCRIPTION	MATERIAL / SPECIFICATION	ITEM NO.
UNLESS OTHERWISE SPECIFIED: DIMENSIONS ARE IN INCHES		CONTRACT NO.	 SKYLOCK INDUSTRIES INCORPORATED MONROVIA, CALIFORNIA, USA	
TOLERANCES .XX ± .03 ANGULAR ± 0 30' .XXX ± .010		CUSTOMER		
DO NOT SCALE DRAWING		DRAWN BY J.L.	LATCH ASSY	
NEXT ASSY	FINAL ASSY	DESIGN		
USED ON	DESIGN ACTIVITY		SIZE C	REV. B
FINISH	ACT WT	CALC WT	FSCM NO. 51941	DRAWING NO. 20621
			SCALE 1/1	RELEASE DATE
			SHEET 1 OF 1	

DRAWING NO. SHEET OF