

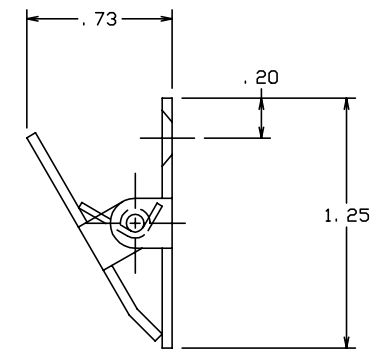

THE INFORMATION AND DESIGN HEREIN WAS ORIGINATED BY AND IS THE PROPERTY OF SKYLOCK INDUSTRIES INCORPORATED. SKYLOCK INDUSTRIES INCORPORATED RESERVES ALL PATENT, PROPRIETARY, DESIGN MANUFACTURING, REPRODUCTION, USE AND SALES RIGHTS THERE TO, AND TO ANY ARTICLE DISCLOSED THEREIN EXCEPT TO THE EXTENT RIGHTS ARE EXPRESSLY GRANTED TO OTHERS. THE FOREGOING DOES NOT APPLY TO VENDOR PROPRIETARY PARTS.

REVISIONS				
ZONE	LTR	DESCRIPTION	DATE	APPROVED
	NC	PRODUCTION RELEASE	2-24-95	T. CSIK

- NOTES: UNLESS OTHERWISE SPECIFIED,  
 1. REMOVE ALL BURRS AND BREAK SHARP EDGES.  
 2. MAT'L: 300 SERIES CRES.  
 3. FINISH: SATIN BRUSH.

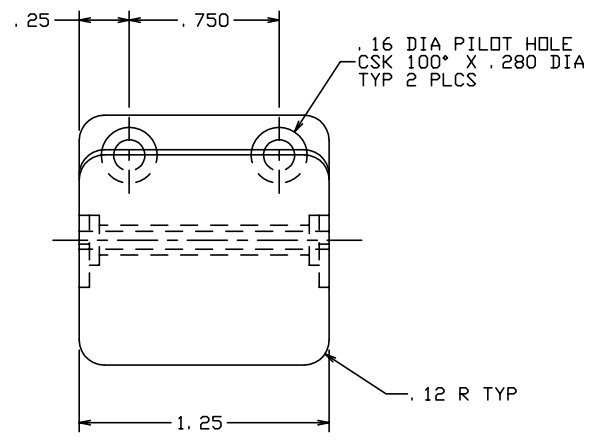

-1		MENU CLIP		
PART NO.	DESCRIPTION	MATERIAL	SIZE SPECIFICATION	ITEM NO.
PARTS LIST				
UNLESS OTHERWISE SPECIFIED	DRAWN BY T. CSIK	2-24-95	 SKYLOCK INDUSTRIES INCORPORATED MONROVIA CALIFORNIA U. S. A.	
DIMENSIONS ARE IN INCHES	CHECKED			
TOLERANCES ON	ENGINEER			
DECIMALS ANGLES DRILLED HOLES	PROJECT			
.X ± .1 ± 0° 30' AND 10387	APPROVAL T. CSIK	2-24-95	MENU CLIP	
.XX ± .03	APPROVAL			
.XXX ± .010				
DO NOT SCALE THIS DRAWING	APPROVAL			
MATERIAL - FINISH	USED ON	SIZE	CODE IDENT. NO.	DRAWING NO.
NEXT ASSY		C	51941	20911
FINAL ASSY		SCALE	2: 1	WT.
				SHEET 1 OF 1

D  
C  
B  
A

D  
C  
B  
A

4      3      2      1

4      3      2      1