

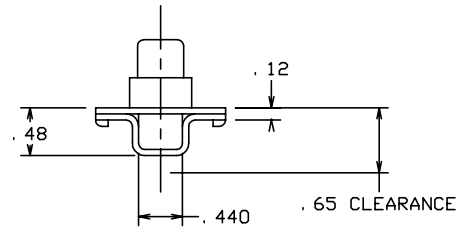

THE INFORMATION AND DESIGN HEREIN WAS ORIGINATED BY AND IS THE PROPERTY OF SKYLOCK INDUSTRIES INCORPORATED. SKYLOCK INDUSTRIES INCORPORATED RESERVES ALL PATENT, PROPRIETARY, DESIGN MANUFACTURING, REPRODUCTION, USE AND SALES RIGHTS THERE TO, AND TO ANY ARTICLE DISCLOSED THEREIN EXCEPT TO THE EXTENT RIGHTS ARE EXPRESSLY GRANTED TO OTHERS. THE FOREGOING DOES NOT APPLY TO VENDOR PROPRIETARY PARTS.

REVISIONS				
ZONE	LTR	DESCRIPTION	DATE	APPROVED
	NC	PRODUCTION RELEASE	6-92	T. CSIK

- NOTES: UNLESS OTHERWISE SPECIFIED.
- REMOVE ALL BURRS AND BREAK SHARP EDGES.
 - MAT'L: HOUSING; ALUMINUM ALLOY, PUSH BUTTON AND BOLT; BLACK NYLON.
 - FINISH: ALUM.; ANODIZE.

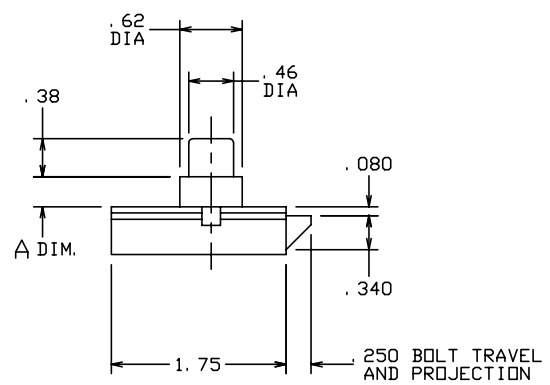
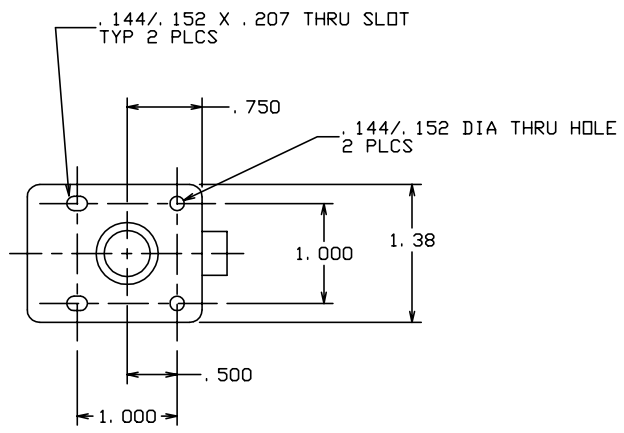

1.00	-7	PUSH BUTTON LATCH	(WEIGHT 0.067 LBS.)
.75	-5	PUSH BUTTON LATCH	(WEIGHT 0.062 LBS.)
.50	-3	PUSH BUTTON LATCH	(WEIGHT 0.057 LBS.)
.30	-1	PUSH BUTTON LATCH	(WEIGHT 0.047 LBS.)
A DIM.	PART NO.	DESCRIPTION	MATERIAL SIZE SPECIFICATION

PARTS LIST					
UNLESS OTHERWISE SPECIFIED	DRAWN BY T. CSIK	6-92	 SKYLOCK INDUSTRIES INCORPORATED MONROVIA CALIFORNIA U. S. A. PUSH BUTTON LATCH		
DIMENSIONS ARE IN INCHES	CHECKED				
TOLERANCES ON	ENGINEER				
DECIMALS ANGLES DRILLED HOLES	PROJECT				
.X ± .1 ± 0° 30' AND 10387 .XX ± .03 .XXX ± .010	APPROVAL T. CSIK	6-92			
DO NOT SCALE THIS DRAWING	APPROVAL				
MATERIAL - FINISH	USED ON	SIZE	CODE IDENT. NO.	DRAWING NO.	REV.
NEXT ASSY		C	51941	20842	NC
FINAL ASSY		SCALE	1: 1	WT.	SHEET 1 OF 1