

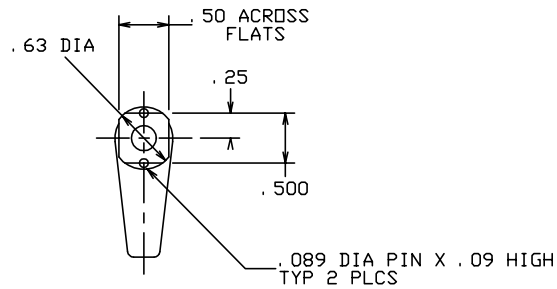
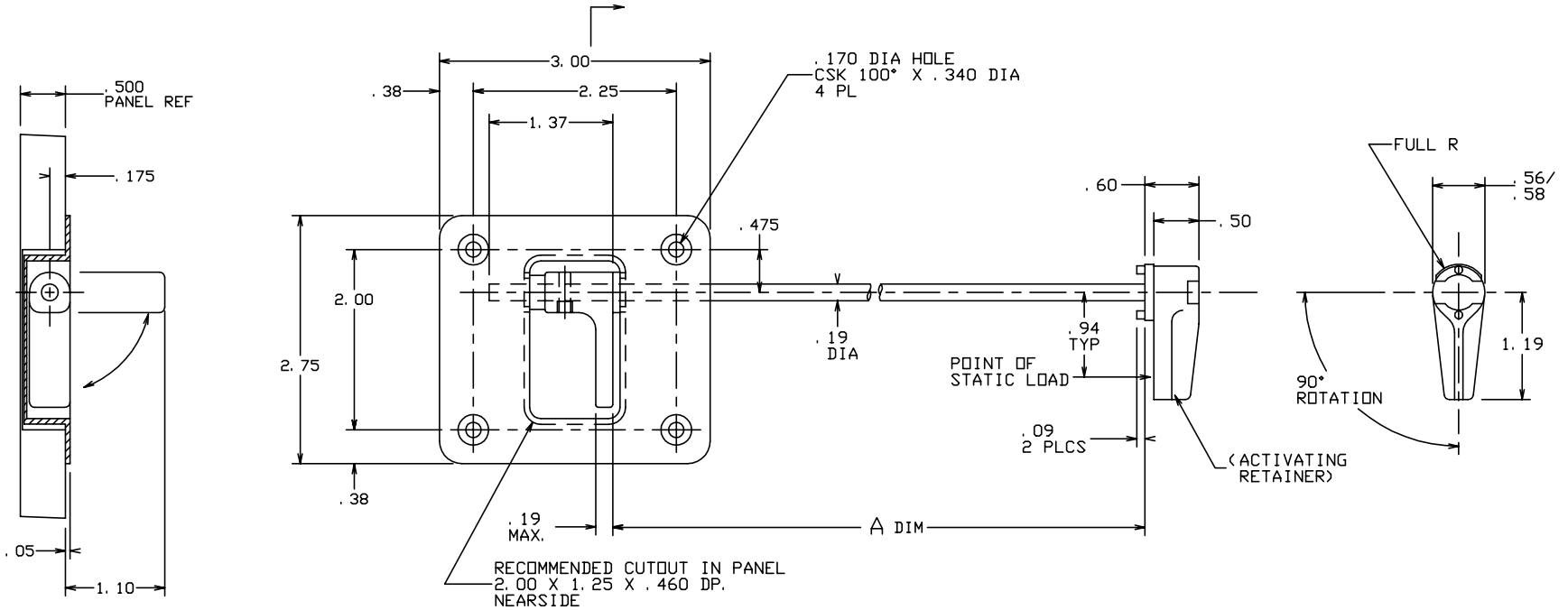

THE INFORMATION AND DESIGN HEREIN WAS ORIGINATED BY AND IS THE PROPERTY OF SKYLOCK INDUSTRIES INCORPORATED. SKYLOCK INDUSTRIES INCORPORATED RESERVES ALL PATENT, PROPRIETARY, DESIGN MANUFACTURING, REPRODUCTION, USE AND SALES RIGHTS THERE TO, AND TO ANY ARTICLE DISCLOSED THEREIN EXCEPT TO THE EXTENT RIGHTS ARE EXPRESSLY GRANTED TO OTHERS. THE FOREGOING DOES NOT APPLY TO VENDOR PROPRIETARY PARTS.

REVISIONS				
ZONE	LTR	DESCRIPTION	DATE	APPROVED
	NC	PRODUCTION RELEASE	2-1-95	T. CSIK

NOTES: UNLESS OTHERWISE SPECIFIED.

- REMOVE ALL BURRS AND BREAK SHARP EDGES.
- MAT'L: ACTIVATING RETAINER AND MOUNTING PLATE; ALUM. ALLOY, ALL OTHER PARTS; 300 SERIES CRES.
- FINISH: ALUM.; ANODIZE, CRES PARTS; PASSIVATE.
- DECORATIVE FINISH: ACTIVATING RETAINER; BRIGHT BUFF AND CANDY APPLE RED ANODIZE.
- STATIC LOAD: 600 LBS. MAX.
- EXAMPLE PART NO.; 20910-1-18.50 = 'A' @ 18.50".



	-402	RETAINER ASSY	(OPP. -401)	
	-401	RETAINER ASSY	(SHOWN)	
PART NO.	DESCRIPTION	MATERIAL	SIZE	SPECIFICATION
PARTS LIST				
UNLESS OTHERWISE SPECIFIED		DRAWN BY	T. CSIK	2-1-95
DIMENSIONS ARE IN INCHES		CHECKED		
TOLERANCES ON		ENGINEER		
DECIMALS		PROJECT		
ANGLES		APPROVAL	T. CSIK	2-1-95
DRILLED HOLES		APPROVAL		
.X ± .1		 SKYLOCK INDUSTRIES INCORPORATED MONROVIA CALIFORNIA U. S. A.		
.XX ± .03				
.XXX ± .010				
DO NOT SCALE THIS DRAWING				
MATERIAL - FINISH		USED ON	SIZE	CODE IDENT. NO.
NEXT ASSY			C	51941
FINAL ASSY				20910
SCALE			1: 1	REV.
SHEET			1	OF 1